

- HINGE FOR WINDOWS AND DOORS WITH GROOVE OF 16 (SHAFT 9 AND SHAFT 13)
- ADAPTABLE TO THE PROFILE OF THE OPENING FRAME 10X14 / 12X15 / 13X16,5 / 14X18.
- PREASSEMBLED FLANGES, SHAFT AND ASSEMBLED SLEEVES.
- CENTRAL SCREW TO AVOID SLIDING.
- MAXIMUM DIMENSIONS: 1000 X 2000 mm.
- MAXIMUM LOAD OF 60KG WITH 2 HINGES AND 70KG WITH 3 HINGES.
- LATERAL SETTING OF +/- 0,7mm. THANKS TO THE ECCENTRIC SLEEVE. (OPTION)
- WATERPROOF GASKET INCLUDED IN THE OPENING FRAME. (PATENTED)
- MAXIMUM RESISTANCE TO CORROSION.

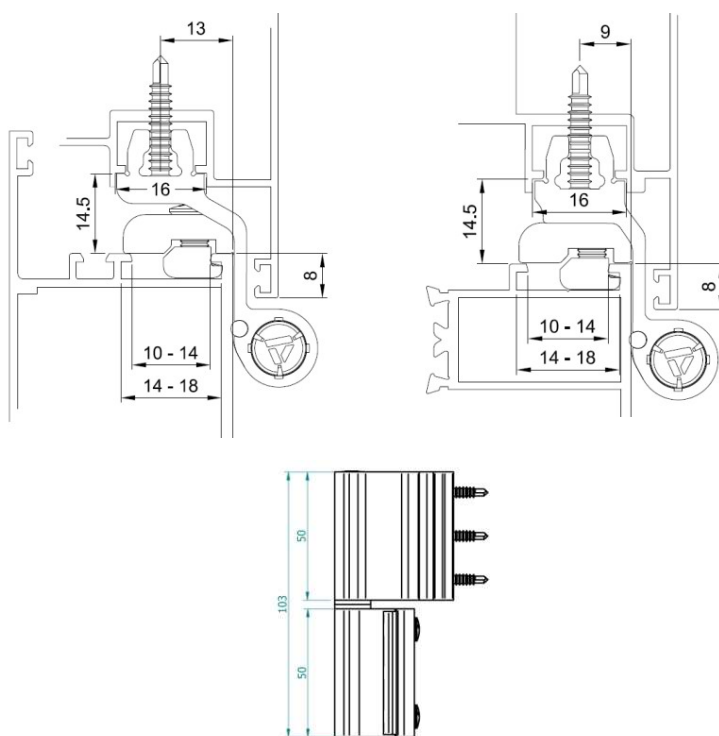

DIMENSIONS (mm)



TEST	STANDARD	RESULT
Resistance to corrosion	UNE-EN 1670	Grade 4

MATERIALS	
Frame	Extruded aluminium
Screws	Stainless steel
Shaft	Stainless steel
Flange	Zamak
Sleeve	Polyamide

FINISHING TOUCHES AND SURFACE TREATMENTS						
WHITE	BLACK	RAL	SILVER	GOLD	BRONZE	INOX

PACKAGING
50 units with preassembled flanges in a 415x215x60 mm box. Eccentric sleeve available