

- TO BE ASSEMBLED ON OPENING AND FIXED FRAMES, WITHOUT ANY NEED TO DRILL.
- MAXIMAL RESISTANCE TO CORROSION

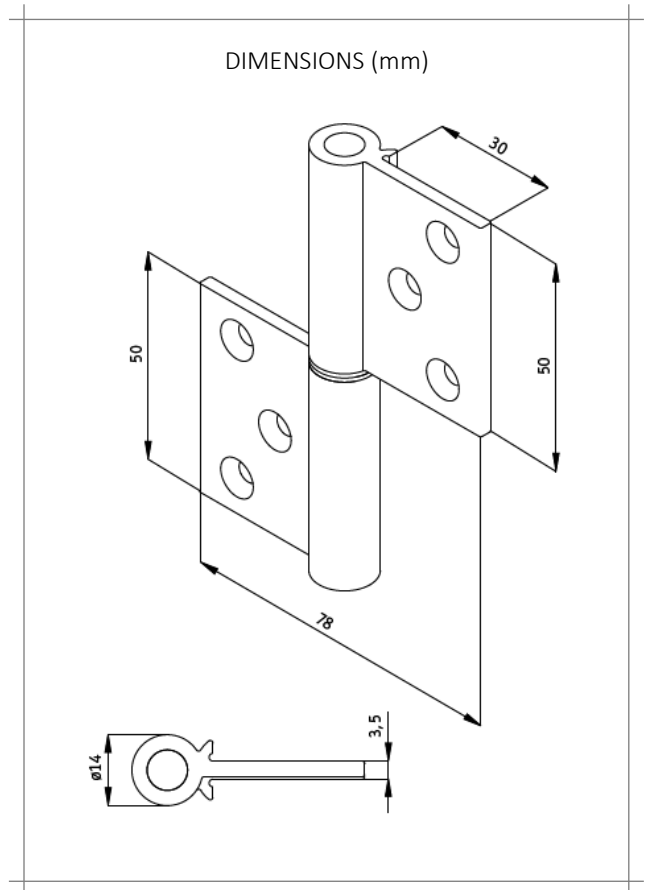

TEST	STANDARD	RESULT
Resistance to corrosion	UNE-EN 1670	Grade 4

MATERIALS	
Frame	Extruded aluminium
Shaft	Stainless steel
Sleeve	Polyamide

FINISHING TOUCHES AND SURFACE TREATMENTS

WHITE	BLACK	RAL	SILVER	GOLD	BRONZE	INOX

PACKAGING

50 units with assembled shafts and sleeves, in a 330x190x75 mm box