

- LEVER CLOSING.
- FIXATION WITH FLANGES.
- FOR 20x183 MACHINING DIMENSIONS.
- POSITION INDICATOR (OPENED/CLOSED).
- MAXIMUM RESISTANCE TO CORROSION.

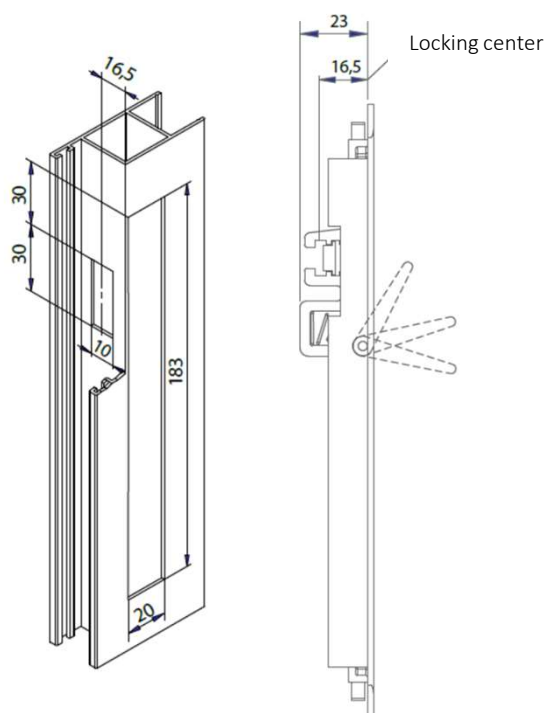

DIMENSIONS (mm.)



TEST	STANDARD	RESULT
Resistance to corrosion	UNE-EN 1970	Grade 4

MATERIALS	
Frame	Extruded aluminium
Sliding	Extruded aluminium
Lever	Polyamide PA6
Plate	Zamak
Screws	Stainless Steel

FINISHING TOUCHES AND SURFACE TREATMENTS

WHITE BLACK RAL SILVER GOLD BRONZE INOX

PACKAGING

20 units packed in a 340x185x73 mm box.
Hooks and keepers sold separately.